

| | | | |
|-----------|--------------|-------------------|---|
| 4 | 3 | 2 | 1 |
| CATEGORY | DESCRIPTION | P/N # | |
| CONNECTOR | BATTERY 7PIN | BA07EM-DB6G1-0000 | |

| | | | | |
|------|--------------|---------------------------------------|---------|------------|
| REV. | ECN NO | DESCRIPTION | REVISED | DATE |
| R01 | | Initial | jack | 2009.04.17 |
| A01 | ECN090810006 | 規格描述中的額定電壓由250V DC變更為50V DC 新版正式發行 | GMC | 2009.08.10 |

SPECIFICATIONS

- CONTACT CURRENT RATING: 2 Amperes.MAX.
- WITHSTANDING VOLTAGE: AC 500V MIN./60S
- INSULATION RESISTANCE: 500 MΩ
- CONTACT RESISTANCE: 50 mΩ MAX.
- VOLTAGE RATING: 50V DC Δ_{A01}
- TEMPERATURE: -25°C TO +90°C.
- SOLDER HEAT RESISTANCE: WAVE SOLDERING 260° 10sec.
- TO CONFORM TO THE "SONY" DIRECTIVE.
- GREEN PRODUCT IDENTIFICATION LABEL IN PACKING: **G.P. PASS**

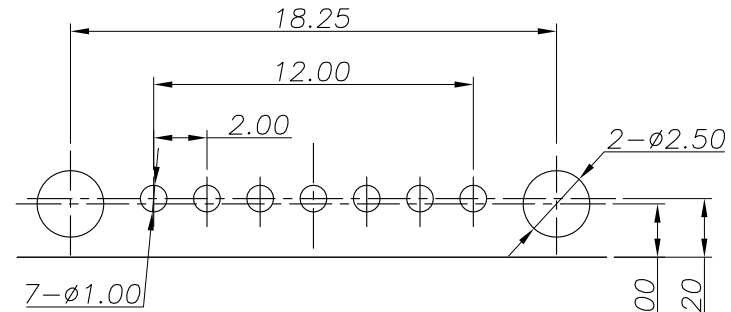
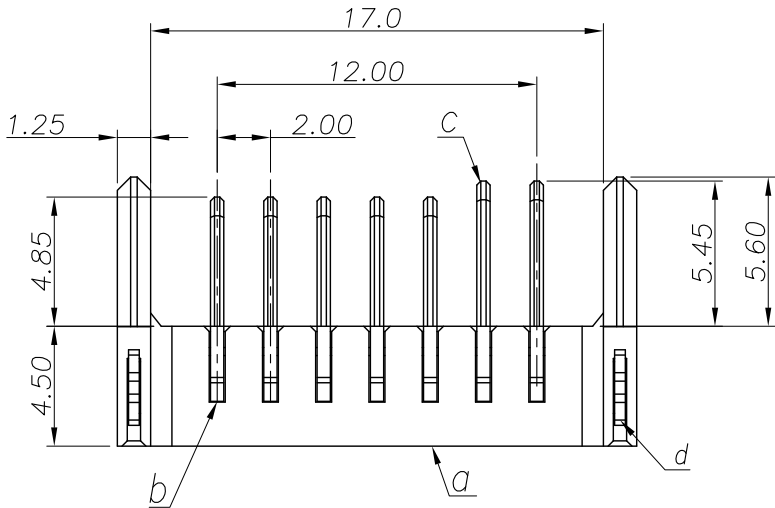
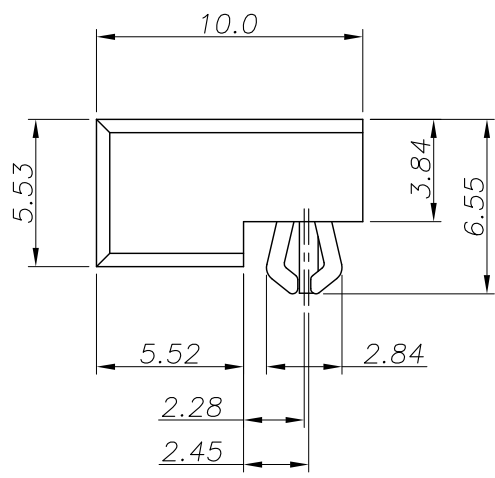
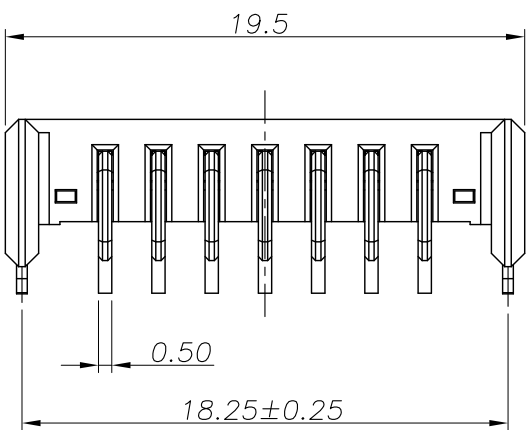

RECOMMEND PCB LAYOUT
 PCB THICKNESS: 1.20mm.
 PCB LAUOUT TOLERANCE: ±0.05mm.

Product Drawing
 ALEXTRONIC

| | | | | | |
|-----|---------------|------|--------------|--------------------|--------|
| d | HARPOON | 2 | BRASS | Tin PLATING | |
| c | LONG CONTACT | 2 | BRASS | Gold Flash Plating | |
| b | SHORT CONTACT | 5 | BRASS | Gold Flash Plating | |
| a | HOUSING | 1 | PA6T UL94V-0 | BLACK | |
| NO. | PART NAME | Q'TY | MATERIAL | PLATING & COLOR | Remark |

| | | | | |
|---|-------------------------------|-------------|------------|-------------|
| UNLESS OTHERWISE SPECIFIED TOLERANCES | SCALE: 1/1 | UNIT: mm | DWG.NO: | |
| | SIZE: A4 | PAGE: 10F1 | REV: A01 | WI-061-453 |
| DECIMALS: X :±0.5 X.X :±0.3 X.XX :±0.2 | ANGLES: X :±2° X.X :±1° | APPROVED BY | CHECKED BY | PREPARED BY |
| | | WYX | PJ | GMC |
| CUSTOMER COPY | | | | |